

(1) SMB Code	(2) Federal Stock Number	(3) Description Reference number & mfg. code Usable on code	(4) Unit Of Meas.	(5) Qty Inc In Unit	(6) 15-day organizational Maintenance alw				(7) Illustration	
					(a) 1-5	(b) 6-30	(c) 31-50	(d) 51-100	(a) Figure No.	(b) Item No.
		1204—HYDRAULIC BRAKE SYSTEM—Continued								
P-O	2530-737-3718	CYLINDER ASSEMBLY: master w/ supply tank assembly 7373718 (19207)	EA	1	*	*	*	*	39	20
P-O	2530-737-3782	EXTENSION: brake pedal pull back spring 7373782 (19207)	EA	1	*	*	*	*	39	21
P-O	2530-737-3783	PEDAL, BRAKE: w/ bearing assembly 7373783 (19207)	EA	1	*	*	*	*	39	22
P-O	2520-454-3998	PAD, DRAFT: brake pedal 7351174 (19207)	EA	1	*	*	*	*	39	23
P-O	2530-522-4179	TUBE, ASSEMBLY, METAL: frame tee to front line, rear 1272531 (12204)	EA	1	*	*	*	*	39	24
P-O	2530-737-5400	CYLINDER, ASSEMBLY, HYDRAULIC BRAKE: left 7375400 (19207)	EA	2	*	*	*	*	39	25
P-O	2530-737-5401	CYLINDER, ASSEMBLY, HYDRAULIC BRAKE: right 7375401 (19207)	EA	2	*	*	*	*	39	25
P-O	5305-225-8496	SCREW, CAP, HEXAGON HEAD: wheel cylinder MS90725-31 (96906)	EA	8	*	*	*	*	39	26
P-O	5310-407-9566	WASHER, LOCK: wheel cylinder MS35338-45 (96906)	EA	8	*	*	*	*	39	27
M-O		TUBE, ASSEMBLY, METAL: frame tee to front line, front 34 - 1/4 inches long 1268699 (12204) Fabricate from:		1					39	28
P-O	4710-277-5525	TUBE, COPPER: seamless BB3338 (50513)	FT	V	*	*	*	*	39	29
P-O	4730-014-2432	INVERTED, NUT, TUBE COUPLING: 142432 (19207)	EA	4	*	*	*	*	39	30
P-O	2530-522-4141	TUBE, ASSEMBLY, METAL: front axle left brake 1268697 (12204)	EA	2	*	*	*	*	39	31

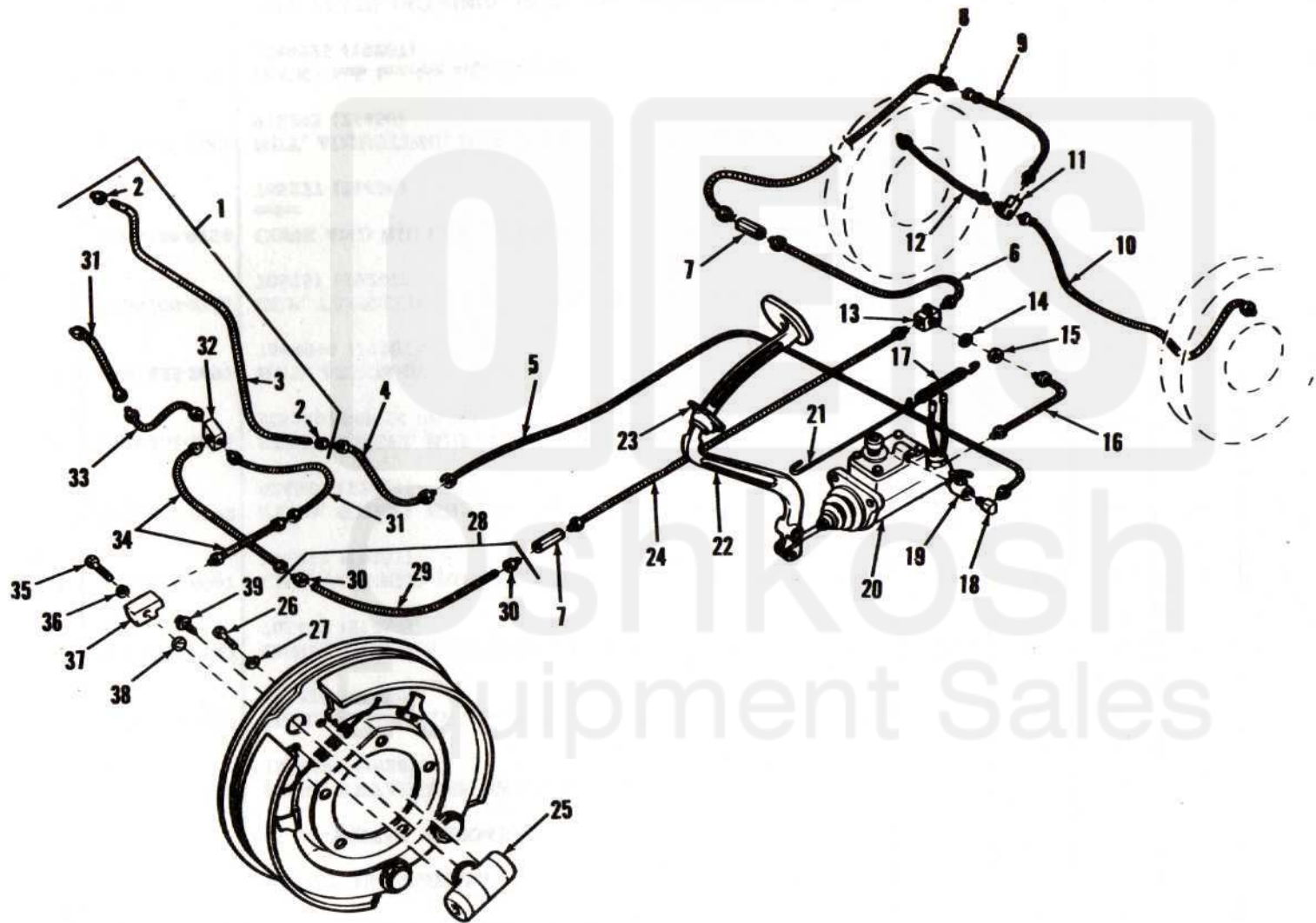

Figure 34 Hydraulic brake system